

SL2190
EXTERNAL MOTOR

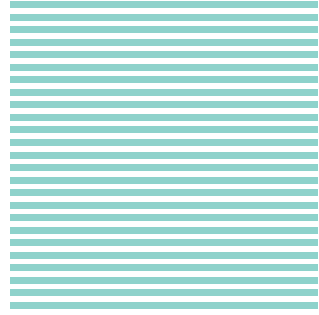

ScreenLine®

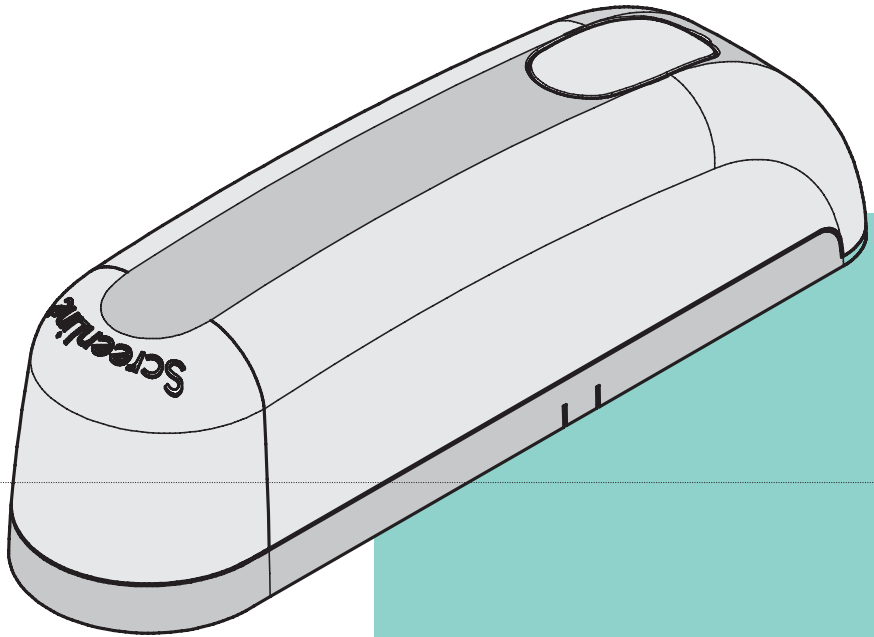

The ScreenLine® external motor can be fitted to all double glazing units that make use of the ScreenLine® frontal magnetic transmission system and allows their tilt, raising and lowering movement.

For easy application and removal (if necessary), the item has been divided into two components: a support and a removable body.

The support contains the external connection contacts and must be applied onto the magnet of the integral blind.

The removable body incorporates the motor and the electrical board. An operation LED, an infra-red receiver and a dip-switch for board configuration can be accessed from the external glass cover.

The motor installed is a rotating-case brushless motor mounted on bearings, directly coupled with the external motor magnet, in order to achieve a direct motion transmission ("Direct Drive" technology). Therefore, no speed redu-

cer or mechanical transmissions or brushes are used, which results in a dramatic reduction in the noise produced by the system.

The electrical board controls the various functions of the motor, including those related to the blind stops (end stops) in its extreme positions. The amperometric protection device allows it to recognise the natural end stops of the blind and memorises them, so that the system will automatically stop in their vicinity (without reaching the limit positions), increasing the lifespan of the blind components; the magnetic transmission system, on the other hand, further reduces the risk of damaging the parts.

The desired end stops of the blind can also be set manually at any height, via some special sequences of pulses to be performed from the external push buttons.

The ScreenLine® external motor must be connected to the corresponding 24V dc power supplier or, using 3.6V dc voltage power, to the

battery-operated ScreenLine system featuring an optional self-charging solar panel. In the latter case, no wiring needs to be done on the window frame.

The motor and, consequently, the blind, operate by means of the polarity inversion of power supply, which can be carried out by means of a couple of push buttons, or via remote control, or by means of the battery module from the battery-operated system.

The dedicated software features two operation speeds so as to optimise and synchronise the slat tilting function, which is also improved by the quartz oscillator.

Should centralised control alongside push button control be requested, it is advisable that one or several SL1807 or SL1963 (radio) control units be used in order to rationally manage several groups of motors.

Technical features

- **Supply voltage:** 3.6 or 24V dc (+/- 10%)
- **Maximum power:** 12 W
- **Stand-by power:** <0.7 W
- **Reduction ratio:** direct
- **Raising speed:** about 1.5 m/minute
- **Dip-switch for board configuration**

- **Receiver for infra-red remote control using 32-kHz frequency**
- **Quartz oscillator for the fine adjustment of the motor speed and the raising movement synchronisation**
- **Control system:** 3-wire input for raising/lowering

- **Operating temperature:** 0-70°C
- **Storage temperature:** -30°C +85°C
- **Relative humidity:** 30-85%
- **Weight:** ~ 300 grams
- **Dimensions:** 136 x 36 x 40 (h) mm
- **Protection degree:** IP40

Installation of the external motor

Preliminary operations

The external motor must be applied onto the double glazing unit only after fitting the latter into the window frame. Make sure that there is sufficient room to accommodate the motor: the internal spacer bar must be aligned or protruding inwards with respect to the glazing bead. Should this not be the case, reduce the thickness of the double glazing unit support blocks.

Arrange the supply cables inside the window frame, close to the position of the magnet of the integral blind, leaving the upper glazing bead open.

Make sure also that the glazing bead has a sealing gasket, in order not to pinch the cables coming out of the electric motor, which must be connected to the power supply. When no gasket is available, cut a slot in the glazing bead, near the area where the cables come out of the motor. Doing this will prevent the cables from being sheared or trapped when the glazing bead is closed.

Attaching the support to the glass

The surface of the glass where the external motor is to be attached must be perfectly clean. Use isopropyl alcohol if necessary and wait a few moments for it to dry.

Arrange the cable outlet from the motor support so that the cables are facing upwards, so that they can enter the upper glazing bead.

Peel off the three protective films from the adhesive tape on the motor support.

Draw the support nearer to the glass, centring it with the internal magnet of the blind. Use the specially supplied cardboard centring piece to help with this. This centring piece has a cutout diameter equal to the external diameter of the magnet located inside the double glazing unit. Make sure that the motor support is parallel with the window frame.

Press the support firmly onto the glass to allow good adhesion, pressing all over its surface against the inside as well.

IMPORTANT: please remove the cardboard centring piece before applying the motor body (see Fig. 3)

Electrical connections

Three wires (white, black and yellow) come out of the outer motor support.

Connect the three wires to the cables coming from the power supply and housed inside the frame. Follow the electrical diagrams in the technical catalogue.

Suitably protect the cable joint and hide the excess cable inside the window frame above the glazing unit.

Close the upper glazing bead, making sure that the cables are not squeezed by it.

Fitting the motor

Insert the motor body, sliding it onto the support until the respective catch at the end of the support clicks.

When the connections are made, ensure that the motor works properly, using the push-buttons connected thereto.

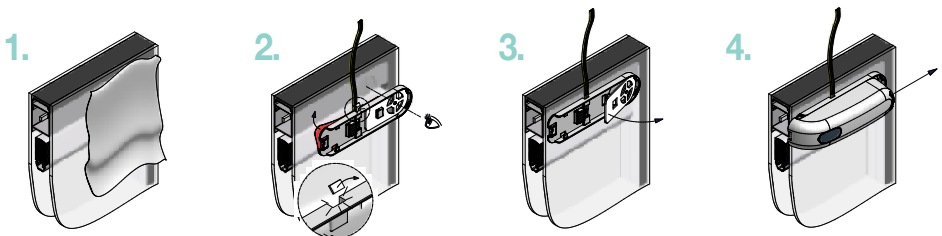

Set-up and adjustment

Setting the end stops

The upward and downward end stops of the blind are memorised automatically (self-learning function) during the first cycle (full raise/lower) of operation of the blind: the amperometric system on the electrical board detects the sudden increase in current and sets the end stop of the blind close to that position. In case of very thick inner glass panes (thicker than 8 mm), the amperometric system may not detect the end stop and the magnet then will slip, without damaging the internal components of the blind or the motor. In this case the end stops must be set using the procedure described below: the same procedure can also be used if the installer wants to set different end stops, at the customer's request (e.g. the tilt only function on venetian blinds). The reset and end stop setting operations can be carried out directly from the external buttons with an appropriate sequence of short pulses, lasting less than three seconds. Each pulse must be

followed by a pause of at least three seconds. At the beginning of the programming procedure, all the values already memorised or set must be cancelled.

To reset the system, with the blind placed in the upper end stop position, raise the blind for 10 to 15 seconds. In order to facilitate the programming sequence, the motor LED is lit in the first 10 seconds and blinks between 10 and 15 seconds.

To programme the upper end stop, take the blind to the required top position, make four short pulses on the up button: up-pause-up-pause-up-pause. To programme the lower end stop, take the blind to the required bottom position, then make four short pulses on the down button: down-pause-down-pause-down-pause-down-pause. If during the setting operation your pulses should more than 3 seconds (which can be checked by the resulting movement of the blind), the programming functions are cancelled and the procedure must be started again.

re must be started again.

In case an infrared remote control is provided, setting the end stops must be done only through pulses from the remote, following the procedure described below. To reset the system, press the central button "S" on the remote control for 4 seconds until the LED lights up confirming that cancellation of the end stops has taken place. To set up the upper end stop: take the blind in the desired top position, then press button S, then press the up button immediately for 4 seconds until the LED lights up, which confirms that programming the upper end stop has taken place. To set up the lower end stop: take the blind in the desired lower position, then press button S, then press the down button immediately for 4 seconds until the LED lights up, which confirms that programming the lower end stop has taken place. Please note that in this case, the external buttons are only enabled for raising, lowering and stopping the blind.

Setting the dip-switches

Under the glass cover there is a dip-switch (see Fig. 1) allowing configuration of the motor electrical board for operating with the integral blind.

To access the dip switches, lift the cover, using the recess in the body.

Dip switch No. 1: width of the cavity

ON: cavity 27 mm or 32 mm

OFF: cavity 20 mm or 22 mm

Dip switch No. 2: Internal blind control device

ON: reduced system

OFF: direct system

Dip switch No. 3: infrared remote control enablement

ON: remote control disabled

OFF: remote control enabled

Dip switch No. 4: type of blind

ON: roller or pleated blind

OFF: venetian blind

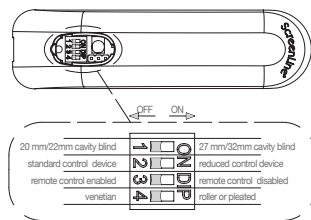

Setting up the infrared receiver

In order to use the external motor with the infrared remote control, the third dip-switch must be set to "OFF", as described above, and the relevant jumper must be removed from the contact accessible from the hole located under the body. It is possible to keep the jumper by placing it onto a single contact pin, as shown in Fig. 2.

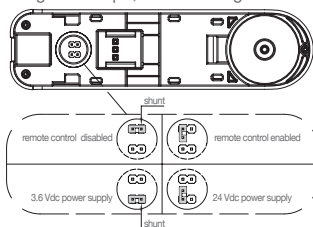

Using the motor with 3.6V dc supply

The external motor can be connected to the battery module in order to achieve self-standing automatic operation. To activate this function, the relevant jumper must be applied onto the contact located under the body Fig. 2 (near the one for activating the infrared remote - see Fig. 2).

Replacing the motor

The body of the external motor can be removed from the glass, without the electric cables having to be disconnected or the glazing bead having to be opened. Push down on the catch located at the bottom of the body (it is in a hidden position, to prevent vandalism). Slide the body out from the support, pushing the body towards its glass cover.

Accessories for the External Motor

The external motor is compatible with all the accessories intended for the internal motor, described in the leaflet "Electrical components for ScreenLine motorised blinds" and, for the battery-operated system, described on the corresponding leaflet devoted to the accessories of model SL20-22F. Should the client so require, he can control the motor via a push-button (to be sourced locally) whose features match the specifications reported in drawings 100, 102 and 103. In cases like this, the black cable must suitably be connected. Please refer therefore to those documents, bearing in mind that, if using all above mentioned accessories, the motor cables to be used for this purpose are the white and the yellow, while the black must NOT be used.

Motor control unit

SL1807



Control unit with integrated radio receiver

SL1963

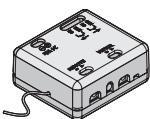

Power supplier for DIN bar

SL2188

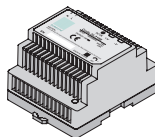

Remote control transmitter

SL1965



Safety instructions

Pellini S.p.A.
ScreenLine External motor mod. SL2190
MAX Torque: 300gr/cm
24V/3.6V dc 0.5A/3.4A; 12W
Continuous operation
IP40; 0°C÷+70°C



- unless they receive caretaking or instruction on the use of the equipment from a person in charge of their safety. Children must be looked after in order to prevent them from playing with the equipment. DO NOT allow children to play with the fixed control devices. Keep the portable (remote) control devices out of children's reach.

Check the equipment on a frequent basis, so as to make sure that no unbalancing or wearing evidence or damage to wires and springs can be detected. DO NOT use the equipment when repairs or adjustment are necessary.

The features of the guided part must be compatible with the rated torque and the rated working time; clearly state how to connect the driving motor to the guided part and how to adjust the control devices.

If the power wires are damaged, they must be replaced by the manufacturer or by its service team, or by a person with equivalent qualification.

Important note

The motor body should be left in its box and not taken out till it is to be fitted to its support. Avoid contact between motor bodies, as the sudden mutual attraction could cause damage to the magnets. When handling the motor body, keep it at safe distance from metal objects that could be strongly attracted by the magnet, as this could also cause damage to the latter. Furthermore, please note that the magnet may attract small metal bodies that may come between the glass and the magnet, this causing the motor fail to operate.

WARNING! Important safety instructions. For people's safety, it is essential that the information here below be followed. Keep this instruction manual.

This equipment is not designed to be used by persons (including children) whose physical, sensorial or mental skills are limited, or who lack the necessary experience or knowledge

2 wires connection with bipolar push-button switch

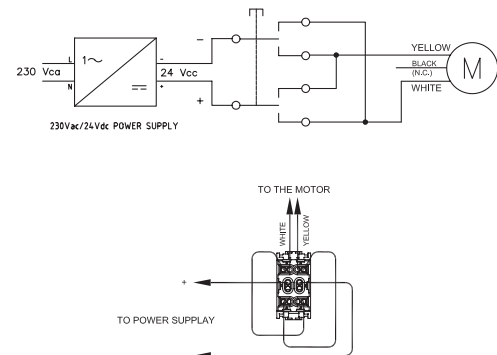

3 wires connection with IR remote control

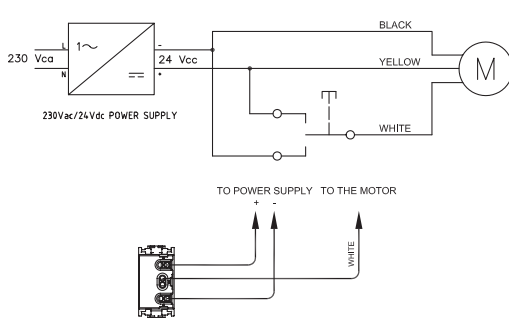

Cable section: 0.35 mm²
Cable length: 2 metri

The company is certified by



ISO 9001: 2008 Certification No. 2351/2

Our products are certified

